



# Introduction to Computer Science

## Sample

## Marking Scheme

This marking scheme has been prepared as a **guide only** to markers. This is not a set of model answers, or the exclusive answers to the questions, and there will frequently be alternative responses which will provide a valid answer. Markers are advised that, unless a question specifies that an answer be provided in a particular form, then an answer that is correct (factually or in practical terms) **must** be given the available marks.

If there is doubt as to the correctness of an answer, the relevant NCC Education materials should be the first authority.

**Throughout the marking, please credit any valid alternative point.**

**Where markers award half marks in any part of a question, they should ensure that the total mark recorded for the question is rounded up to a whole mark.**

<b>Answer ALL questions</b>
-----------------------------

**Marks**

**Question 1**

- a) Computers are available in different sizes and are used for many different purposes. However, they share common characteristics.
- i) Identify THREE (3) main functions of a computer system. **3**  
**Award 1 mark for each valid point to a maximum of 3 marks.**
- **Input of data**
  - **Output of information**
  - **Processing of data**
  - **Storage of data/information**
- ii) Identify TWO (2) essential components of a computer system. **2**  
**Award 1 mark for each valid point to a maximum of 2 marks.**
- **Hardware**
  - **Software**
- b) The amount of data that is processed and stored by computers is increasing.
- i) Identify TWO (2) types of computer that can be used to store mass volumes of data. **2**  
**Award 1 mark for each valid point to a maximum of 2 marks.**
- **Supercomputer**
  - **Mainframe**
- ii) Describe THREE (3) requirements of a computer system that stores and processes large amounts of data. **3**  
**Award 1 mark for each valid point to a maximum of 3 marks.**
- **Large storage capacity**
  - **Fast processing speeds**
  - **Fast retrieval speeds**

**Total 10 Marks**

## Question 2

- a) The most important hardware component of a computer system is the central processing unit (CPU). The following diagram shows the main components of a CPU.

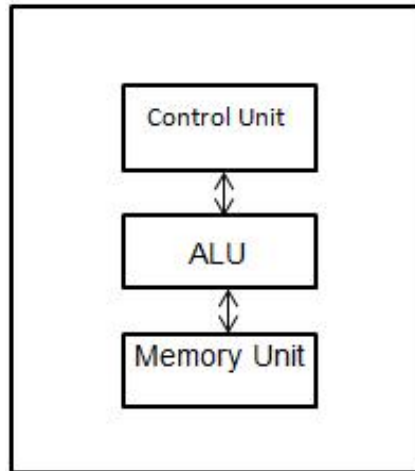

- i) Explain the purpose of the arithmetic and logic unit (ALU). 3  
**Award 1 mark for each valid point to a maximum of 3 marks.**
- **Calculations are performed in the ALU**
  - **In the arithmetic part of the ALU, operations such as add, subtract, multiply and divide are performed**
  - **In the logic part of the ALU, numbers are compared through functions such as = equal to, < less than, > greater than and not equal to**
- ii) Describe the function of a bus in relation to a CPU. 2  
**Award 1 mark for each valid point to a maximum of 2 marks.**
- **A bus connects the CPU to other components**
  - **It carries instructions and data around a system**
- b) An essential component of a computer is a motherboard.
- i) Identify THREE (3) main components of a motherboard. 3  
**Award 1 mark for each valid point to a maximum of 3 marks.**
- **CPU/microprocessor**
  - **Memory chips**
  - **Basic input/output system (BIOS)**
  - **Circuitry**
  - **Expansion slot**
- ii) Describe the function of a motherboard. 2

**Marks**

**Award 1 mark for each valid point to a maximum of 2 marks.**

- **It connects the components of a computer**
- **It connects the CPU, memory, hard drive, optical drive, video card, sound card, ports, expansion cards**

**Total 10 Marks**

## Question 3

- a) Briefly describe one feature of a closed source operating system.  
Award 1 mark for any valid point, such as: 1
- The source code of the operating system is not published/shared
  - The source code of the operating system cannot be changed/customised/tweaked
  - The company that developed it provides technical support
  - The software is developed/improved by large number of a company's programmers
- b) For each of the following statements, state whether it is an example of a *multithreading operating system*, a *multitasking operating system* or a *real-time operating system*.
- i) An operating system that allows more than one program to run at the same time. 1
- A multitasking operating system. (1 mark)
- ii) An operating system that responds to input instantly. 1
- A real-time operating system. (1 mark)
- iii) An operating system that enables different parts of a single program to run at the same time. 1
- A multithreading operating system (1 mark)
- c) A number of criteria should be considered when obtaining application software, for example, whether a software licence is required or whether to use integrated software.
- i) Explain THREE (3) purposes of a software licence. 3  
Award 1 mark for each valid point to a maximum of 3 marks.
- It offers protection to software companies/software writers against unauthorised use of software
  - It contains information on how/when the software can be used
  - It states restrictions on the use of software
- ii) Describe THREE (3) features of integrated software. 3  
Award 1 mark for each valid point to a maximum of 3 marks.
- It contains several application programs, e.g. word processing, spreadsheet and presentation
  - Each program/application has a similar layout and interface to the other programs/applications
  - Data can be transferred easily between each program.

Total 10 Marks

Question 4

- a) i) In the table below are examples of THREE (3) image file formats. Identify if each one uses *lossy* or *lossless* compression. 3

Image file format	Type of compression used
PNG	
GIF	
JPEG	

Award 1 mark for each correct answer to a maximum of 3 marks.

Image file format	Type of compression used
<b>PNG</b>	<b>Lossless compression</b>
<b>GIF</b>	<b>Lossy compression</b>
<b>JPEG</b>	<b>Lossy compression</b>

- ii) Describe TWO (2) features of an image if it is compressed using lossy compression. 2

Award 2 marks for each valid point to a maximum of 2 marks.

- It is smaller when compressed
- Its quality is affected
- Some of the data is removed from the image so it is not exactly the same when it is decompressed
- It facilitates faster loading of an image on a website

- b) Logic gates enable a digital system to make decisions based on the inputs to the logic gate.

- i) Identify which logic gate the following symbol represents. 1

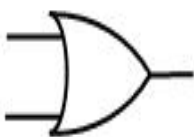

Award 1 mark.

- OR gate

- ii) Identify FOUR (4) functions of a logic gate. **4**
- Award 1 mark for each correct answer to a maximum of 4 marks.**
- **Two digital signals are input to the gate/circuit**
  - **The gate/circuit compares the signals**
  - **The gate/circuit makes a decision**
  - **A new signal is output from the gate/circuit based on the decision made**

**Total 10 Marks**

## Question 5

- a) A departmental manager wants to upgrade the computer network that is currently used in her department. She has chosen the following network topology to be used:

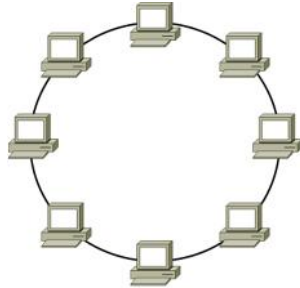

- i) Identify the network topology that the departmental manager has chosen. 1  
**Award 1 mark for the following:**
- Ring topology
- ii) Outline FOUR (4) advantages of choosing this topology. 4  
**Award 1 mark for each valid point to a maximum of 4 marks.**
- It will not be expensive to set up
  - It will not be difficult to expand
  - It will not be difficult to maintain
  - Data transfer should be quick
  - Data collisions should be minimal
- b) It is important that respect is shown to other users when using computers. It is also essential that organisations who store data on people do so with due regard to the law.
- i) Explain briefly what is meant by *netiquette*. 2  
**Award 1 mark for each valid point to a maximum of 2 marks.**
- Respecting other users' views when online
  - Displaying courtesy when posting views to online discussion groups/sending or distributing e-mail/chatting
  - Socially responsible Internet use
- ii) Describe THREE (3) aims of the UK Data Protection Act 1998 3  
**Award 1 mark for each valid point to a maximum of 3 marks.**
- It sets out rules on how data should be stored/used
  - It aims to protect personal data
  - It aims to ensure that personal data is processed as the law said it should be
  - It gives rights people to access/see data stored about them
  - It aims to ensure that data is accurate and up-to-date

Total 10 Marks

End of paper



**Marking note**

Multiply original mark out of 50 by two to produce final mark out of 100 to be recorded.

**Learning Outcomes matrix**

Question	Learning Outcomes assessed	Marker can differentiate between varying levels of achievement
1	1	Yes
2	2	Yes
3	1	Yes
4	3	Yes
5	4 and 5	Yes

**Grade descriptors**

Learning Outcome	Pass	Merit	Distinction
Understand fundamental concepts relating to hardware and software	Demonstrate adequate level of understanding	Demonstrate robust level of understanding	Demonstrate highly comprehensive level of understanding
Understand the characteristics of hardware components	Demonstrate adequate level of understanding	Demonstrate robust level of understanding	Demonstrate highly comprehensive level of understanding
Understand how data is represented in a computer system	Demonstrate adequate level of understanding	Demonstrate robust level of understanding	Demonstrate highly comprehensive level of understanding
Understand the fundamental concepts of computer networks	Demonstrate adequate level of understanding	Demonstrate robust level of understanding	Demonstrate highly comprehensive level of understanding
Understand cultural, ethical and legal issues relating to computing	Demonstrate adequate level of understanding	Demonstrate robust level of understanding	Demonstrate highly comprehensive level of understanding